

# **DEVELOPING AN OPTIMAL PRODUCT LINE USING CONSUMER PREFERENCES AND COST DATA**

**Steve Cohen  
Susan Stoev**

**Much of the activity of market researchers focuses on understanding the effect of new products on the firm. By researching product acceptance before introduction, manufacturers recognize that careful attention to consumer wants and needs will increase their likelihood of success. This paper provides a case study of the challenges that faced both a client firm (Eastman Kodak Company) and its research partner (SHC & Associates) in developing research to study consumer acceptance of potential entrants in four new product lines being contemplated by Kodak. The paper first addresses the challenges faced by the internal researcher in drawing out the needs of product management, having them accept the possibilities and limitations of consumer research, and developing an understanding of the study findings and uses of the research when the study is complete. Secondly the paper addresses the challenges faced by the research agency in developing a research design and program that fits the needs of the client, implementing that design, and developing findings that can be easily understood and implemented.**

---

## **KODAK'S CHALLENGE**

Eastman Kodak Company is a major worldwide manufacturer and marketer of imaging products including digital cameras and accessories. The digital camera line is an important contributor to Kodak's sales and profits, and as photography shifts from silver halide technology to digital technology, this camera line and its accessories will become even more important. In 2001, Kodak introduced the EasyShare Camera Dock, the heart of the EasyShare system. Consumers just place the camera in the dock, press a button, and pictures are automatically transferred to the computer. The dock also charges the camera's battery and serves as a convenient place to store the camera when not in use. The EasyShare dock solved a major problem with digital photography, making it easy to get images into the computer.

**Figure 1**  
**KODAK EASYSHARE CAMERA AND DOCK**

---



Consumer research, however, showed that it was not enough. Over 60% of digital camera owners wanted to print more of their digital images than they currently did, but found the process of printing at home unsatisfactory. Consumers were looking for higher quality output that was quick and easy. So the company embarked on ways they could solve the next major consumer dissatisfier: getting high quality prints from their digital camera. Like many other manufacturers, there were many products in Kodak's pipeline that could solve this consumer need. The challenge was deciding which of these opportunities had the biggest potential for the company.

One of ideas being considered was the concept of combining the original EasyShare dock with a high quality photo printer, a product later to be known as the Kodak EasyShare Printer Dock 6000. As with the original camera dock, the "dock" part of the product would allow the consumer to transfer digital images to a computer and charge the digital camera's battery. The "printer" part was designed so that the consumer could easily print long-lasting photo-quality images without having to go through the computer. Thus, the printer dock would simultaneously solve several of the major complaints made by digital camera owners about using their camera.

---

**Figure 2**  
**KODAK EASYSHARE PRINTER DOCK 6000**

---



---

This project started with a simple question: do consumers like the idea of a printer dock? But the more we got into it, the more we realized it wasn't a simple question at all. Being that each camera manufacturer uses a different connection to a dock or PC, the printer dock being developed could only be used with a Kodak camera. Would consumers considering another camera brand switch to a Kodak camera if Kodak had the printer dock? Or would we be better off with a dedicated photo printer that worked with all camera brands? Since these devices only made 4x6 photos, would consumers buy a dedicated photo printer/printer dock, or would they opt instead for an inkjet printer that could print both regular documents and all size photos? The dock had been a very successful product, but how much would a printer dock cannibalize dock sales? As these questions were raised, additional questions from management surfaced. For example, since we really haven't decided on the product features, could we test a few different versions of each? And what happens if another manufacturer beats us to market? By the time we were finished defining the problem, we had seven brands, five product categories, three or four different products within each category at three price levels – for a total of over 1,000 possible combinations that people could choose! The challenge was clear:

- Which of the four different types of accessories (docks, printer docks, dedicated photo printers or inkjet printers) would consumers be most interested in buying?
  - Within each type of accessory, which of the good-better-best products should be manufactured and marketed first, second, etc.? At what price should they be offered so as to generate the highest consumer adoption rate and the most profit?
-

- Which competitors had the most “equity” in the four potential product lines and less in others?
- What effect did the availability of a product have on brand choice? That is, if Kodak only offered a “good” dock and another manufacturer offered a “best,” would the consumer switch brands?
- Which consumers are attracted to which kind of accessory?
- Finally, what might be the potential adoption rates in each of three major Kodak markets: United States, United Kingdom, and Germany?

Behind these specific questions were some additional challenges:

- The project specifications had changed from testing one new product to testing a product line. Kodak had done many single new product tests but had not confronted a situation with so many potential products.
- In a single new product test, consumers choose to buy (or not) just the product being tested. In this case, since consumers were essentially making a choice of a digital camera system (camera alone or camera with one or more printing or dock accessories), the “shelf set” and the task had to accommodate a free choice by consumers, rather than a single product choice.
- Since certain accessories only worked with a camera of the same brand, consumers’ choices had to be constrained to incorporate this issue.
- Kodak realized that several prior new product tests had delivered less than expected results because the consumers were not as fully informed about the products as they should have been.
- Kodak wanted a simulation tool that incorporated all of their issues, and yet was easy to use so that it could be installed on the PC of a marketing or product manager.
- Finally, rather than focusing on market share potential, Kodak wanted to investigate the effects different cost and pricing assumptions on *profit*, not share.

To develop a research plan that would meet all these needs, Kodak engaged SHC & Associates to provide the business acumen, research and questionnaire design skills, and marketing science expertise to meet the myriad challenges and needs of management. Kodak had used this firm several times in the past few years, especially in situations involving large, complex research projects in new product areas.

---

## **The Research Agency Challenge**

Briefly, the challenges to the research agency included:

- What research design would be needed to have consumers evaluate over a dozen products from each of seven manufacturers?
- How would the design accommodate the presence or absence of certain products from each manufacturer, so as to understand the effects of only one product in an accessory line being available versus two or all three?
- How would we educate consumers, so as to maximize their understanding of product functions and prices, and thus make more informed decisions?
- How would we develop a statistical model that would allow individual-level estimates of all the needed effects?
- What simulation techniques and tools would be used to allow managers to develop what-if scenarios of future market conditions?

## **RESEARCH DESIGN**

We believed that some sort of trade-off analysis would be needed as the main data collection exercise. Furthermore, a free choice exercise that allowed picking multiple products from a shelf set of several manufacturers would be needed. And then before these tasks were to be completed, we realized that a heavy dose of consumer education would also be needed.

Conjoint Analysis and its extensions have been developed to optimize the features, functionalities, and price so as to design a product that will meet the needs of the most number of consumers. The typical flaw in these analyses, however, is that what may be optimal for the consumer is probably sub-optimal for the firm. Specifically, we do not hesitate to generalize and say that consumers want the most features for the lowest price, while manufacturers would like to offer the fewest features for the highest price. We contend that standard Conjoint Analysis market simulators that optimize features and price for the highest choice share are missing the point and produce sub-optimal solutions for the firm. Hence, market simulators for Conjoint Analyses that combine consumer preference information with internal cost data are more robust.

---

## METHODOLOGY

One thousand in-person interviews in total were conducted in the United States, the United Kingdom, and Germany during the second half of 2002. Each interview lasted about one hour and included a series of product descriptions and simulated shopping trips. About half the respondents were digital camera owners and half were intenders who planned to purchase a digital camera soon.

### Step 1: Develop a plan for the research flow

We decided to approach this problem in two parts. First, we would introduce the product categories one at a time and get detailed consumers reaction. This insured that respondents had a good understanding of each of the different product types and they articulated what they liked or disliked about each.

**Figure 3**  
**RESEARCH FLOW DIAGRAM**

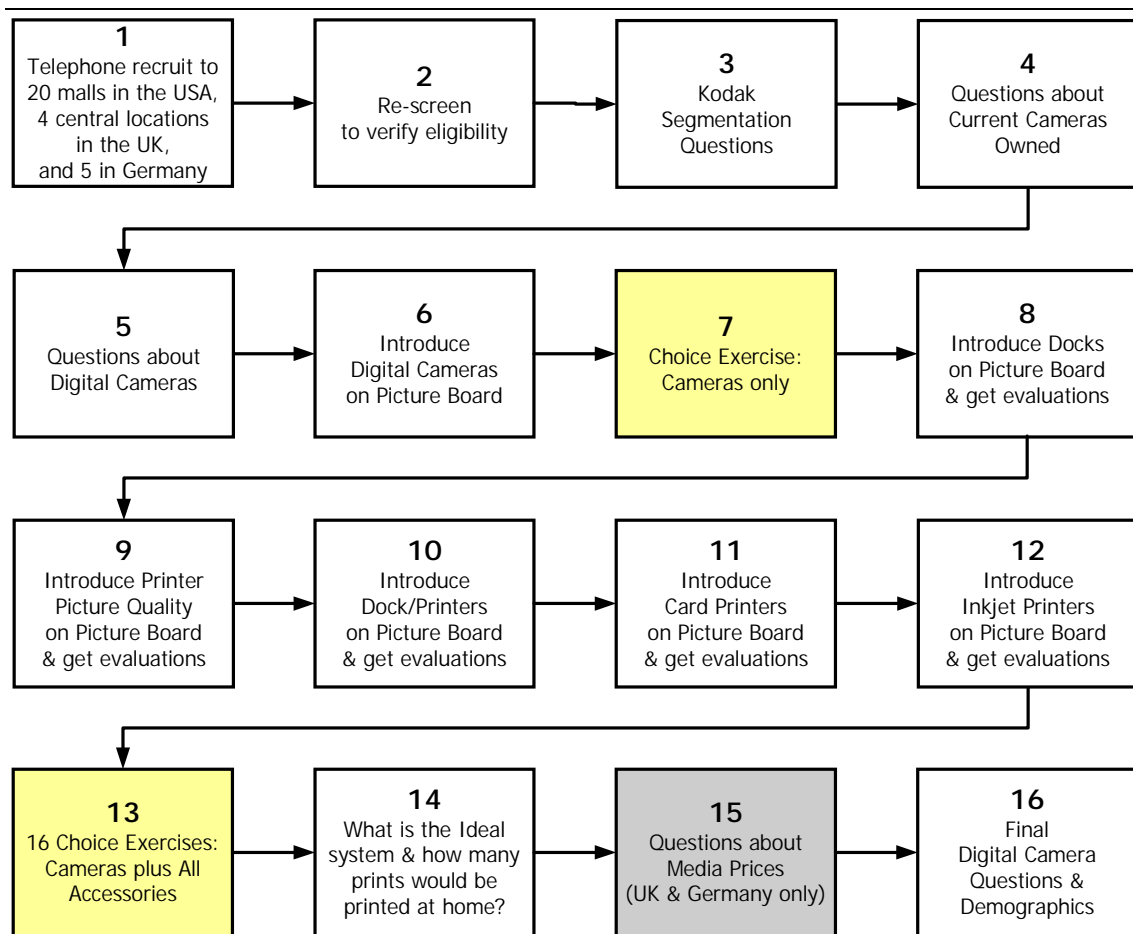

## **Step 2: Make product comparisons easy**

Well-laid out concept boards were critical to the education process. They gave us an easy way of explaining product features to respondents so they fully understood the differences between product categories and individual models before doing the choice exercise. We developed a series of seven concept boards, each being sequentially introduced and placed on a table in front of the respondents. As the education proceeded, the interviewer read a narrative explaining the purpose of each product and the similarities and differences between the products in that accessory category. The interviewer would point to the board to highlight key differences, and then the respondent was asked product preferences within each category. (See figure 4.)

As we were designing the boards themselves, several points were evident:

- Illustrations need to de-emphasize styling.
    - \* Watch for subtle differences like shadows, button placement, rounded edges.
  - Picture samples, used to demonstrate image quality, need to be *exactly* the same.
    - \* Respondents will often react to the content of the picture, i.e. the little girl is cute.
  - Use a reference point to convey size.
    - \* All products here shown on a tile counter.
  - All features for the product category should be listed beside each product.
    - \* We used checkmarks and shading to show whether feature is present.
    - \* The title of each accessory category was a different color, again to emphasize differences.
-

**Figure 4**  
**SAMPLE CONCEPT BOARD**

## 4"x6" Photo System Printers: Direct from Camera

4



### Basic photo system printer dock

- Prints 4"x6" borderless photo quality pictures
- Connects to TV for slide show
- Select pictures to print
  - Only on camera
  - On camera, printer (using camera display), or TV
- Print directly from camera
  - Put camera in dock, press print
  - Connect a cable to printer, and press print
- One touch picture transfer to PC
- Battery charges while camera is in dock
- Use with or without PC
- Pictures are waterproof and last for generations
- Priced from \$79 - \$129
- Cost/print ranges from 50 cents to 80 cents

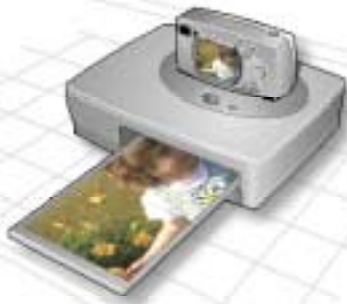

### Plus photo system printer dock

- Prints 4"x6" borderless photo quality pictures
- Connects to TV for slide show
- Select pictures to print
  - Only on camera
  - On camera, printer (using camera display), or TV
- Print directly from camera
  - Put camera in dock, press print
  - Connect a cable to printer, and press print
- One touch picture transfer to PC
- Battery charges while camera is in dock
- Use with or without PC
- Pictures are waterproof and last for generations
- Priced from \$99 - \$149
- Cost/print ranges from 50 cents to 60 cents



### Premium photo system printer dock

- Prints 4"x6" borderless photo quality pictures
- Connects to TV for slide show
- Select pictures to print
  - Only on camera
  - On camera, printer (using camera display), or TV
- Print directly from camera
  - Put camera in dock, press print
  - Connect a cable to printer, and press print
- One touch picture transfer to PC
- Battery charges while camera is in dock
- Use with or without PC
- Pictures are waterproof and last for generations
- Priced from \$149 - \$299
- Cost/print ranges from 50 cents to 60 cents



### Photo system printer: no dock

- Prints 4"x6" borderless photo quality pictures
- Connects to TV for slide show
- Select pictures to print
  - Only on camera
  - On camera, printer (using camera display), or TV
- Print directly from camera
  - Put camera in dock, press print
  - Connect a cable to printer, and press print
- One touch picture transfer to PC
- Battery charges while camera is in dock
- Use with or without PC
- Pictures are waterproof and last for generations
- Priced from \$129 - \$279
- Cost/print ranges from 50 cents to 60 cents

**Step 3: Help the interviewer do his/her job well**

As researchers, despite our best efforts, interviewers are never as engaged in the product category and all the nuances of them as we would like interviewers to be. In this case, we would be presenting seven concept boards to consumers and asking that they be evaluated one at a time. In the final task, consumers would have to choose freely across the seven boards, so all of the boards must be easily seen by the respondent. In early pretests, we realized that we had to give the interviewer some help.

Since the boards had to be shown and placed in a specific order, we used tape to mark the spot on the interviewing table that each board should be placed, somewhat like theater companies do to help actors/actresses find their spots.

Figure 5 shows the final placement of all seven boards (1a-6), the respondent, the interviewer and the questionnaire on an interviewing table.

**Figure 5**  
**PLACEMENT DURING INTERVIEW**

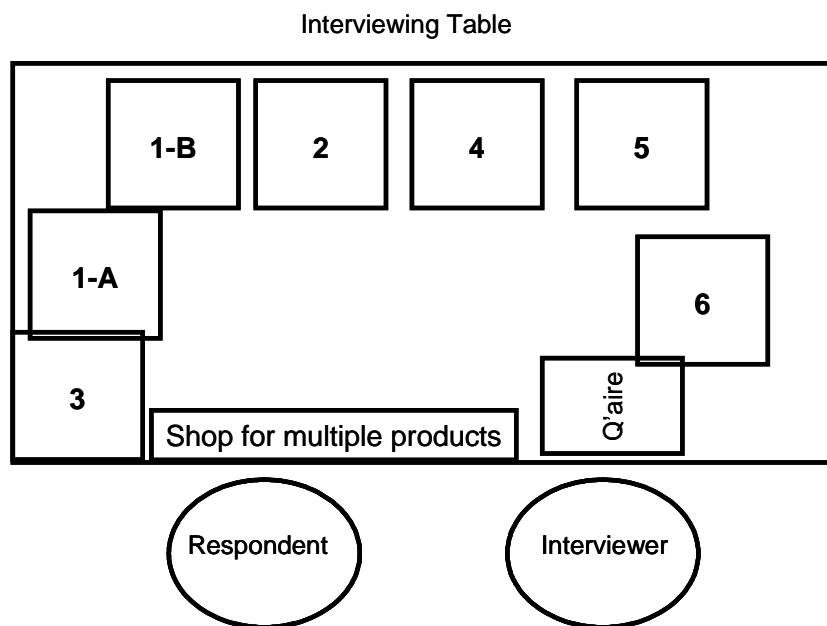

**Step 4: Do an extensive pretest**

We cannot emphasize strongly enough the value of an extensive pretest to the development of the questionnaire. One member of the research agency conducted the interviews at a focus group facility, while the main client contact was in the back room watching. While we expected each interview to last about 45 minutes, we deliberately allocated one hour and a half for each pretest, to accommodate questions from the “moderator,” and feedback from

---

the pretest respondent. Although we only completed eight interviews, the value received from these, including questionnaire changes “on the fly,” contributed greatly to an extensive re-writing of the questionnaire and a significantly better research instrument. Of course, we allocated enough time to make changes to the concept boards as a result of the pretest.

**Step 5: Design the product menu to make choices easier**

Now that consumers had a good understanding of the options available they were ready to begin the choice exercise – shopping for a camera system. Each respondent completed through 16 choice exercises using an easy-to-interpret menu card.

**Figure 6**  
**MENU CARD – SHOPPING TRIP 1**

		FUJI		HP		Sony	
These items represent the three brands of digital cameras	Digital Cameras	Fuji FinePix	\$120 <input type="checkbox"/>	HP Photo Smart	\$199 <input type="checkbox"/>	Sony Cybershot	\$220 <input type="checkbox"/>
		Fuji FinePix With optical zoom	\$199 <input type="checkbox"/>	HP Photo Smart With optical zoom	\$199 <input type="checkbox"/>	Sony Cybershot With optical zoom	\$260 <input type="checkbox"/>
	Camera Docks	Fuji Basic	\$49 <input type="checkbox"/>				
		Fuji Premium	\$69 <input type="checkbox"/>	HP Plus	\$29 <input type="checkbox"/>	Sony Plus	\$79 <input type="checkbox"/>
	Photo System Printers (Direct from Camera)	Fuji w/ no Dock	\$179 <input type="checkbox"/>	HP Basic	\$129 <input type="checkbox"/>	Sony w/ no Dock	\$279 <input type="checkbox"/>
		Fuji Plus	\$129 <input type="checkbox"/>	HP Plus	\$129 <input type="checkbox"/>	Sony Premium	\$299 <input type="checkbox"/>
These printers can use either the "T" brand or their own	Photo Card Printers (Direct from Memory Card)	HP Basic	\$99 <input type="checkbox"/>	HP Plus	\$149 <input type="checkbox"/>		
		Kodak Basic	\$79 <input type="checkbox"/>				
				Epson Plus	\$149 <input type="checkbox"/>		
		HP Premium (with CD writer)	\$299 <input type="checkbox"/>	Kodak Premium (with CD writer & color LCD)	\$249 <input type="checkbox"/>		
	Kodak Premium (with CD writer)	\$199 <input type="checkbox"/>					
	Canon Premium (with CD writer)	\$249 <input type="checkbox"/>					
	Sony Premium (with CD writer)	\$299 <input type="checkbox"/>					
	Multipurpose Printers (Inkjet)	Canon (no card reader)	\$119 <input type="checkbox"/>	Canon (with card reader)	\$169 <input type="checkbox"/>		
		Epson (no card reader)	\$129 <input type="checkbox"/>	Kodak (with card reader)	\$149 <input type="checkbox"/>		
	I would buy NONE of these <input type="checkbox"/>						

*If you were shopping for digital cameras and saw these options, what would you choose?*

Before they were asked to make choices from these cards, we also showed them a series of “correct” and “incorrect choices” (e.g. mismatched brands, product duplications, etc.) Thus the respondents were fully educated about what they were buying, what product combinations made a complete “system,” and which combinations did not. An example of a menu card is shown in figure 6 above.

Note that accessory categories were segregated from one another, product availability was represented by an open check box with a price next to it, and only three to four brands out from the seven under study were shown on any menu. Columns represented brands, and rows the product categories. Additionally, instructions on the left of the card showed when a consumer had to choose a product that was the same brand as their camera, and when it could be a different brand.

The prior education proved to be invaluable. Consumers knew going into the choice exercise what they were most interested in, were able to complete the task quickly and gave us very consistent results. Furthermore, our experience shows that it often takes consumers several choice cards to figure out what is important to them, leading to data inconsistencies between the choices made in the beginning and the end. Showing them correct and incorrect choices first made it easier for the respondent to complete the task. Finally, we also had the interviewer double-check the respondent’s choices for inconsistencies. This made for a very clean dataset to work with.

The simulated shopping trips consisted of choosing to buy from a menu of up to 46 different products from seven manufacturers (with brand names being rotated across trips). In summary, eight generic choices were available for the consumer:

1. A digital camera *only*
  2. A digital camera *and* Dock from the same brand
  3. A digital camera *and* Dock from the same brand plus a Photo Card Printer from ANY brand
  4. A digital camera *and* Dock from the same brand plus a Multipurpose Printer from *any* brand
  5. A digital camera *and* Printer Dock from the same brand
  6. A digital camera *and* Photo Card Printer from ANY brand
  7. A digital camera *and* Multipurpose Printer from ANY brand
  8. *Or*, the consumer could choose to buy “None of these” and re-evaluate their purchase decision on the next shopping trip.
-

A dock, for example, could be marketed by six different camera manufacturers and could be from one of the good-better-best categories. This means that the second option above really represents 18 potential product choices. In all, there were 1,003 potential choices (including 'none') for each consumer, counting all brands and product configuration. Since we were also testing several different prices for each of these products, the number of combinations available was astronomical.

### **MENU-BASED CONJOINT ANALYSIS**

Some readers will look at this study and say that Conjoint Analysis would be an appropriate solution. A traditional Conjoint Analysis is *not* appropriate here because consumers are presented with multiple products and are *freely choosing what they want to buy*.

We asked consumers to look at a “menu” of available products at the “time of purchase at a store,” and then choose a combination from the menu that best suited their needs. One can think of this as the consumer customizing the choices to provide a system solution (one of the 1,002 alternatives) to their individual needs.

To truly meet consumers' needs in this scenario, the competitive game for firms must shift from having a fully-featured product that might satisfy the needs of potential buyers to having a full range of products with differing features, functionality, and prices that the buyer can pick and choose from. So instead of having pre-assembled digital camera system consisting of a camera plus one or more accessories, the customer must be able to build his own solution by choosing from a menu of products.

Hence, the key marketing challenge is to identify the products and their features that should be on the menu (e.g. be available in the store), to understand how customers want to build customized digital imaging system solutions, and to understand how to price each product, so as to increase customer value and, at the same time, maximize company revenues and profits.

Implementing this approach must be done with the use of a menu task. Menus are nothing new to all of us. Consider how a restaurant mass customizes meals. The diner chooses exactly those products (appetizer, entree, dessert, and beverage) that satisfy his hunger. The problems for the restaurant owner are what to items put on the menu (product), how much of each ingredient to stock (raw materials), and how to price each menu item (pricing) to deliver a good meal to the diner and to make money in the process (revenues and profits). This not an easy task – especially without a marketing scientist on staff at all restaurants!

---

But how should you design and analyze marketing research to better understand choice from a menu? Understanding products consisting of discrete features seems like something that Conjoint Analysis should be able to handle. But the complexity of the menu situation renders traditional Conjoint inappropriate.

Menu-based Conjoint Analysis (MBCA), an extension of Choice-based Conjoint Analysis (CBCA), was developed by Liechty, Ramaswamy, and Cohen<sup>1</sup> to handle the customized menu situation. CBCA presents respondents with several buying situations composed of competitive alternatives. The task is to choose the *one* best alternative – which may include “none of the above” – in each situation that best meets their needs. Choice alternatives are designed so that they differ systematically on features and prices.

In MBCA, the respondent sees several menus that differ systematically on the prices of each product on the menu, and perhaps even which products are, or are not, on the menu. The consumers’ task is to choose none, one, several, or even all the product alternatives from those available (in our case, the eight generic alternatives).

In Conjoint Analysis, the levels of each feature are typically not priced individually and are varied independently of the price of the whole product. When using MBCA, each product is priced separately and the buyer picks exactly those products at the prices shown that satisfy their system needs.

The traditional Conjoint task requires the respondent to evaluate each product profile or choice situation and then to provide one reaction to the whole product. In contrast, MBCA will ask the respondent to examine several menus and to provide a “buy-not buy” reaction to each product on the menu. The number of responses for each menu is not a single overall “buy-not buy” as in traditional Conjoint, but rather a series of such responses. If there were 15 products on a menu, this would require 15 yes/no answers, yielding *32,768 potential product combinations for just that one menu, not counting the price levels being tested!* Again, the important difference here is that traditional Conjoint or CBCA will yield one answer per each profile or scenario. MBCA could require  $k$  answers, where  $k$  is the number of products on the menu.

Upon analysis of Conjoint data, the analyst decomposes the product profile reactions into the constituent parts or utilities that are attributable to each level of each feature. In contrast, since the MBCA task obtains from one to  $K$  reactions to each profile (where  $K$  is the number of products), we directly obtain a separate utility for each product and its features and prices, rather than decomposing the reaction to the whole product into its component parts.

---

## MODEL ESTIMATION

Estimation of the menu model results may be accomplished by traditional aggregate statistical techniques (e.g. Multinomial Logit, Multinomial Probit, and Multivariate Probit). These tools develop one equation that describes the preferences of the average respondent.

In this case, Kodak needed to understand the preferences and behaviors of individual consumers and thus Hierarchical Bayes estimation techniques were used, as described by Sawtooth Software (2001):

*“Hierarchical Bayes is a relatively new technique for computing individual-level part worths from (choice) data. HB has been described favorably in several recent journal articles. Its strongest point of differentiation is its ability to provide estimates of individual part worths given only a few choices by each individual. It does this by ‘borrowing’ information from other individuals.”*

It is beyond the scope of this paper to describe HB fully. We refer the interested reader to the references.

Briefly, HB methods assume that each parameter being estimated (conjoint utilities) is described by a distribution across people, perhaps with constraints like price utilities must be negative, with a mean value and variability around the mean. We also assume that, given those parameters, the likelihood of some outcome (choice, rating) can be described by a statistical model, like MNL, MNP, or MVP.

The benefits of using HB include:

- incorporate prior information when available;
- obtain estimates of each utility for each person, when multiple questions (i.e. conjoint cards, choice sets, or menus) are asked;
- obtain estimate of heterogeneity in the population, and potentially within an individual “Borrows information” from others to stabilize estimates.

The drawbacks of HB include:

- HB models are based on Monte Carlo simulation principles. Thus, complicated or large models may take a long time to converge. In this case, we fit 71 parameters to 1,000 respondents, each of whom completed 16 menus, with each menu having 1,003 alternatives.
  - Easily available software is often limited by the constraints on their software, making estimation of large models (like this one) impossible.
-

- Especially when estimating the utilities of features like price, HB tends to smooth the distribution of prices across people, making it difficult to find post hoc segments based on the utilities. Alternative procedures, like Latent Class Models, assume there is “lumpiness” in the data and these lumps describe the location of segments.

## SIMULATION

The history of using simulators to predict market performance from Conjoint data is long. As mentioned earlier, most Conjoint simulators do not take product manufacturing and distribution costs into account, and thus are deficient in finding a truly optimal solution for the firm. Figure 7 is a schematic of our simulator’s inputs and outputs:

**Figure 7**  
**SCHEMATIC OF SIMULATOR’S INPUTS AND OUTPUTS**

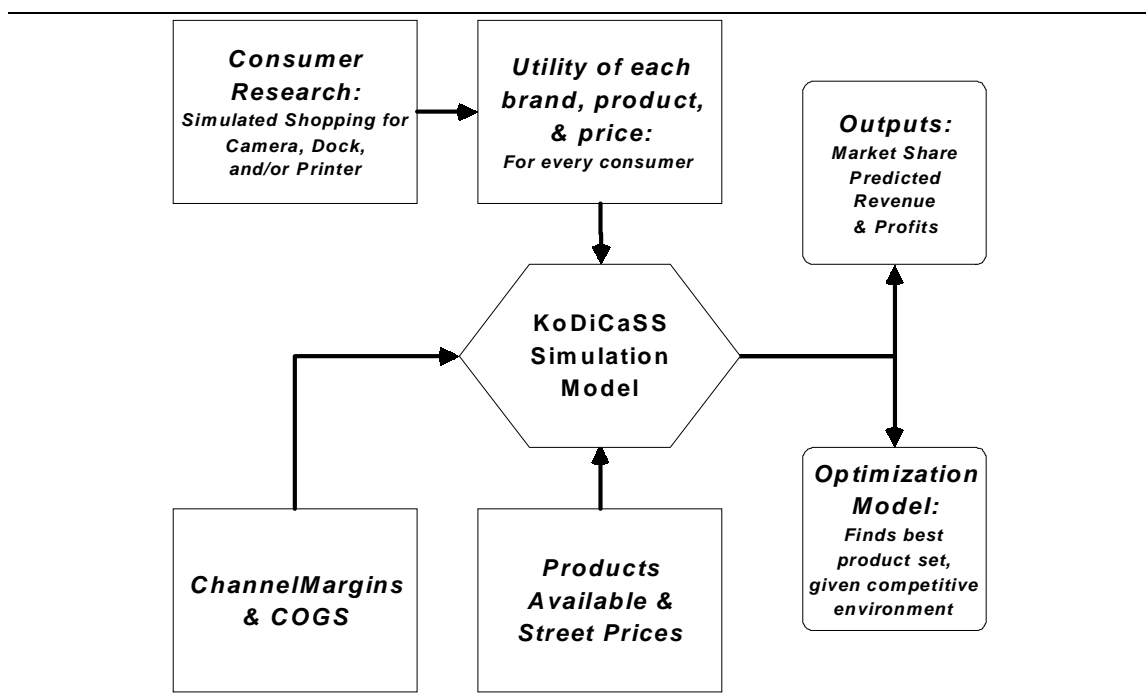

We developed a market simulator in Excel that incorporated these features:

- individual consumer preference data, based on the 71 parameters derived in the HB estimation;
  - a simple input screen so that managers could define a marketplace of products with their prices;
-

- a simple input screen for assumed product costs and consumer consumption of consumable accessories (e.g. paper and ink);
- output of market share, revenues, and profit index based on each scenario defined by the manager
- multiple views of the output results, including views by brand, by accessory category, and by system solution chosen;
- ability to choose results for pre-defined segments (e.g. photo experience or age), as well as the ability to define segments based on multiple criteria (e.g. young, inexperienced photographers);
- ability to optimize share, revenue, or profit, based on vary the prices charged for each product.

The simulator was linked to a calculation engine written in C++, so that the heavy calculations would be done outside Excel, and Excel would be used for the display of results.

The academic literature is replete with papers on optimization and simulation models. Three features characterize the methods used in the marketing literature:

- Function optimized: maximize share, revenue, or profits
- Choice rule: deterministic or probabilistic
- Products: Single or multiple

Typical optimization solutions may be characterized by how the solution is developed. Analytic solutions use complex mathematics with an equation or a series of equations to find a single best solution to the problem. Enumeration entails listing every possible solution and then sorting them from best to worst. For small problems, enumeration is easily accomplished; for large problems, enumeration may be time-prohibitive. And finally, “solvers” have been developed to find a series of “best” or “almost best” solutions, but in dramatically less time than enumeration.

The tool we used is a Genetic Algorithm. Again while we do not have the space to describe these in detail, GAs are new optimization tool with several key advantages.

- GAs use non-linear programming methods which are more robust than linear models.
  - GAs are flexible and can handle many different model structures.
  - GAs are easily implemented, in fact we purchased a GA add-in for Excel.
  - GAs are fast and converge to optimal or near-optimal results very quickly.
  - GAs are accurate at finding optimal solutions.
-

Using a GA with Conjoint data to study product line optimization has been studied only once in the literature that we are aware of (Steiner and Hruschka, 2002). The innovation that we included, which Steiner and Hruschka did not, is the estimation of the Conjoint utilities with HB techniques. To demonstrate, while Steiner and Hruschka provide an analysis of *five* potential products in the line for *one* manufacturer, our situation is much more complex: *six* manufacturers, *five* product lines, up to *four* configurations in each line from each manufacturer, for a total of 90 potential products. A GA Excel add-in (NeuroDimensions, 2003) was used for optimization.

### **CLIENT'S PERSPECTIVE ON RESULTS OF THE STUDY**

This study showed Kodak that the printer dock had much stronger consumer appeal than the universal printer, and full-scale production began immediately. The EasyShare Printer Dock 6000 was introduced in the United States in March 2003, and study results have almost exactly predicted in-market performance. A study of this complexity had never been done by the Digital & Applied Imaging Division (D&AI), and for the first time Kodak was able to:

1. *Show that it is possible to explain multiple levels of new product concepts to consumers and have them complete an extremely complicated choice exercise with excellent results.* Previously, most research on this product concept had been qualitative in nature using product props and competitive products – product planners and marketing people love this approach because they get to “hear the voice of the consumer”, but it doesn’t provide the level of precision needed to make complicated tradeoff decisions. Initially there was skepticism that consumers would not be able to handle all of the information we were asking them to process. However, a good study design and clear explanation of the products proved to be effective.
  2. *Quantitatively prove the value of the dock to the system portfolio.* Predicted camera share went up significantly when Kodak was the only manufacturer to offer a dock. The same relationship held with printer docks – the concept of an easy to use integrated system has remarkable appeal. This had a tremendous effect on the way Kodak looks at its product line. Previously, docks and dock/printers had been thought of as “accessories” to cameras. This research showed that providing consumers with a complete solution could influence their camera choice. Consequently, marketing communications materials, advertising strategies and merchandising practices have all been changed to reflect a systems message. Retailers love it because of the higher margins they are able to make on multiple product sales. And most importantly, the consumer wins
-

- with an integrated solution to a previously unmet need – satisfaction and likelihood to recommend the printer dock have set all time records at 95%!
3. *Estimate what happens when competitors enter the market with similar products.* Some brands represent a significant threat, while others have little effect. Kodak now knows which brands they have to worry about, and can use the simulator to determine the strategy they should employ. It is not necessary to react the same way to all competitors.
  4. *Use quantified data to determine the optimal introduction price, taking into account all elements of the value chain.* The simulator utilizes the retail price, cost of goods sold, dealer margin, media prices and consumption rates of paper and ink by brand and type of product. A complete picture of potential profit that includes cameras, printer docks and media use can now be used to make decisions. As the figure 8 below shows, the printer dock should be introduced at the highest price even though the percent of people choosing it is the lowest. The loss of revenue from the lower printer dock price was not made up in additional volume.

**Figure 8**  
**PREDICTED PERCENT BUYING AND**  
**PREDICTED PROFITS AT THREE PRICE POINTS**

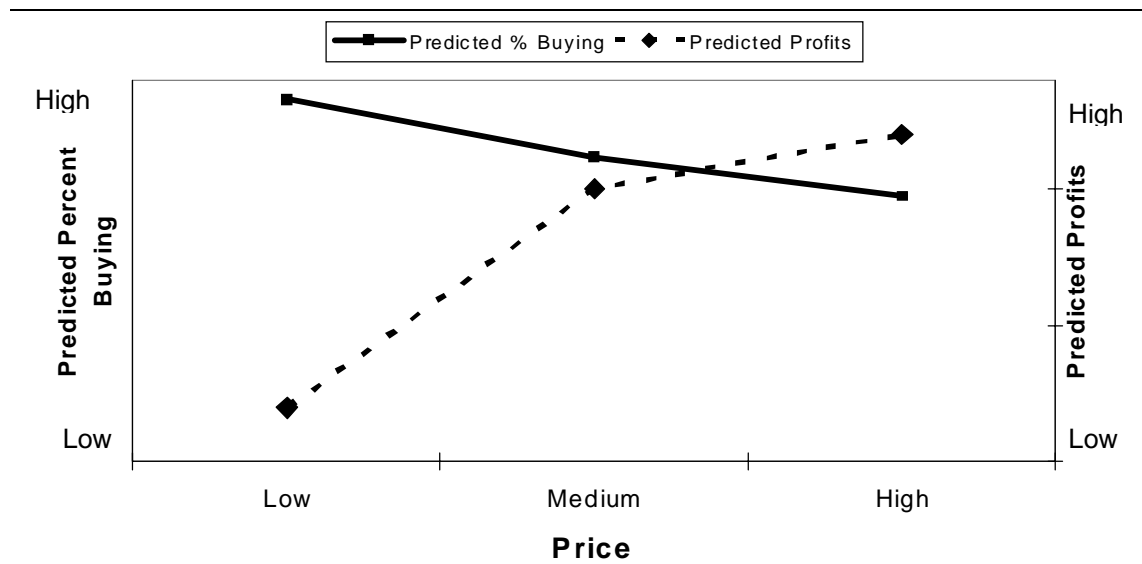

5. *Have an easy-to-use simulator to make decisions about future portfolio additions.* Kodak continues to evolve its printer dock product line using results from the simulator. The tool is being used by both marketing and product planning to better understand pricing, brand strength and future product profitability.

6. *Translate the study findings to numbers that would aid decision-makers.* One of the challenges of this study was to explain how to translate the results into market estimates. There were camera shares, dock / printer dock shares, attach rates (the percent of people buying both a camera and a dock or dock printer) and predicted profit, and managers weren't sure which number they should be looking at. The first hurdle was to get management to use the predicted profit calculation as the major qualifier. This one measure is the best estimate of total Kodak performance, taking into account both cameras, docks/dock printers and the expected stream of media use over the next three years. Predicted profit tells you which products and associated prices had the biggest impact and should be introduced first. The attach rate is then used to determine what percentage of cameras are expected to sold with docks or with a dock printer, and the predicted split between them (i.e. x% docks, 100-x% dock printers). As Kodak camera production is capacity constrained, the actual camera production number is known in advance. We could then use the following equation to get an estimate of printer dock volume:

$$\text{Camera production} * \text{Attach Rate} * \text{Proportion Printer Dock}$$

7. *Estimate the risk associated with the predicted estimates of camera share.* The study predicted a higher camera base share than is currently experienced in the market. This was expected, given that no manufacturer enjoys 100% awareness and distribution in actual market. Consequently, the impact on camera share was looked at as a change to a base case number rather than an actual number. For example, in one scenario tested, the simulation results predicted that camera share would increase from x to y% once a printer dock was introduced – a 50% increase. We can then take our actual market share and increase it by 50% to get feel for potential impact on camera volumes. Therefore, once the introductory product and price were set, managers had to only remember three numbers – the predicted attach rate, the percent of that which would be printer docks and the potential increase in camera share. Additionally, the simulator was written to allow a +/- 90% confidence estimate around any forecast. This allowed Kodak to further estimate risks.

In conclusion, excellent partnership between SHC Associates and Kodak provided significant decision-making input for managers to enable the quick commercialization of the EasyShare Printer Dock, a product that now plays an important part in the future of the Eastman Kodak Company.

---

**FOOTNOTE**

1. The paper by Liechty, Ramaswamy, and Cohen was a finalist for the 2001 Paul E. Green award, given annually to the paper that appeared in the previous year's *Journal of Marketing Research* that "shows the most promise of influencing the fields of marketing and marketing research over the next five years."

**REFERENCES**

- Allenby, Greg M. and James L. Ginter. (1995). Using extremes to design products and segment markets. *Journal of Marketing Research*, 32, pp. 392-403.
- Allenby, Greg M. and Peter. E Rossi. (1999). Marketing models of consumer heterogeneity. *Journal of Econometrics*, 89:1-2, pp. 57-78.
- Balakrishnan, P.V. and V.S. Jacob. (1996). Genetic algorithms for product design. *Management Science*, 42:1, pp. 1105-1117.
- Cattin, Phillipe and Dick Wittink. (1982). Commercial use of Conjoint Analysis: A survey. *Journal of Marketing*, 46:3, pp. 44-53.
- Cohen, Steven H. (1997). Perfect union: CBC marries the best of Conjoint and discrete choice models. *Marketing Research Magazine*, Spring, pp. 12-17.
- Cohen, Steven H. (1998). Review of 'Multi-featured products and services: Analyzing pricing and bundling strategies' by Moshe Ben-Akiva and Shari Gershensfeld. *Journal of Forecasting*, 17, pp. 203-205.
- Gelman, Andrew, John B. Carlin, Hal S. Stern and Donald B. Rubin. (1995). *Bayesian Data Analysis*. New York: Chapman & Hall.
- Gilks, W.R., S. Richardson and D.J. Spiegelhalter (1996). *Markov Chain Monte Carlo in Practice*. London, UK: Chapman & Hall.
- Green, Paul E. and Abba Krieger. (1985). Models and heuristics for product line selection. *Marketing Science*, 4, pp. 1-19.
- Green, Paul E. and Abba Krieger. (1987). A simple heuristic for selecting 'good' products in conjoint analysis. *Applications of management Science*, 5, pp. 131-153.
- Green, Paul E. and Vithala Rao. (1971). Conjoint measurement for quantifying judgmental data. *Journal of Marketing Research*, 8, pp. 355-363.
- Green, Paul E. and V. Srinivasan (1990). Conjoint Analysis in marketing research: New developments and directions. *Journal of Marketing* 54:4, pp. 3-19.
- Kohli, Rajeev and Ramesh Krishnamurti. (1987). A heuristic approach to product design. *Management Science*, 33, pp. 1523-1533.
- Kohli, Rajeev and R. Sukumar. (1990). Heuristics for product line design using Conjoint Analysis. *Management Science*, 36, pp. 1464-1478.
-

- Lenk, Peter, Wayne S. DeSarbo, Paul E. Green, and Martin R. Young. (1996). Hierarchical Bayes Conjoint Analysis: Recovery of partworth heterogeneity from reduced experimental designs. *Marketing Science*, 15, pp. 173-191.
- Liechty, John, Venkatram Ramaswamy, and Steven H. Cohen. (2001). Choice menus for mass customization: An experimental approach for analyzing customer demand with an application to a Web-based information service. *Journal of Marketing Research*, 38, pp. 183-196. Finalist for Paul E. Green award.
- Louviere, Jordan J. (1988). *Analyzing Decision Making: Metric Conjoint Analysis*. Sage University Papers Series in Quantitative Applications in the Social Sciences, No. 67, Newbury Park, CA.
- Louviere, Jordan J. and George Woodworth. (1983). Design and analysis of simulated consumer choice or allocation experiments: An approach based on aggregate data. *Journal of Marketing Research*, 20, pp. 350-367.
- Louviere, Jordan and David S. Bunch (1998). Discussion of 'Multi-featured products and services: Analyzing pricing and bundling strategies' by Moshe Ben-Akiva and Shari Gershensfeld. *Journal of Forecasting*, 17, pp. 197-201.
- McFadden, D. (1974). Conditional logit analysis of qualitative choice behaviour, in Zarembka P. (ed.), *Frontiers in Econometrics*, New York: Academic Press, pp. 105-142.
- McFadden, D. (1986). The choice theory approach to marketing research. *Marketing Science*, 5 (4), pp. 275-297.
- Moore, William, Jordan J. Louviere, and Rohit Verma. (1999). Using Conjoint Analysis to help design product platforms. *Journal of Product Innovation Management*, 16, pp.27-39.
- NeuroDimension, Inc. (2002). *Genetic Server*. <http://www.nd.com/genetic/>
- Ben-Akiva, Moshe and Shari Gershensfeld (1998). Multi-featured products and services: Analyzing pricing and bundling strategies. *Journal of Forecasting*, 17, pp. 175-196.
- Sawtooth Software. (2001). *CBC Hierarchical Bayes analysis technical paper*. Sawtooth Software: Sequim, WA.
- Slywotzky, Adrian J. (2000). The age of the choiceboard. *Harvard Business Review*, January-February, pp. 40-41.
- Steiner, Winfried J. and Harald Hruschka. (2002). A probabilistic one-step approach to optimal product line design problem using Conjoint and cost data. *Review of Marketing Science Working Papers*, 1(4).
- Wind, Jerry and Vijay Mahajan (1997). Issues and opportunities in new product development: An introduction to the special issue. *Journal of Marketing Research*, 34, 1, pp. 1-12.
- Wittink, Dick R. and Philippe Cattin (1989). Commercial use of Conjoint Analysis: An update. *Journal of Marketing*, 53, pp. 91-6.
-

Urban, Glen L. and John Hauser. (1993). *Design and marketing of new products*. New Jersey: Prentice-Hall.

### **THE AUTHORS**

Steve Cohen is Principal, SHC & Associates, United States.

Susan Stoev is Director, Digital & Applied Imaging Research, Eastman Kodak Company, United States.

---

## APPENDIX

**Figure 9**  
**SAMPLE CONCEPT BOARD: DIGITAL CAMERA WITH OPTIONAL ZOOM (1B)**

---



**Canon PowerShot**  
☑ with optical zoom  
☑ Priced from \$179 - \$299

---



**Fuji FinePix**  
☑ with optical zoom  
☑ Priced from \$149 - \$249

---



**HP PhotoSmart**  
☑ with optical zoom  
☑ Priced from \$149 - \$249

---



**Kodak EasyShare**  
☑ with optical zoom  
☑ Priced from \$149 - \$249

---



**Olympus Camedia**  
☑ with optical zoom  
☑ Priced from \$179 - \$299

---



**Sony CyberShot**  
☑ with optical zoom  
☑ Priced from \$179 - \$299

---

**Figure 10**  
**SAMPLE CONCEPT BOARD: CAMERA DOCKS (2)**

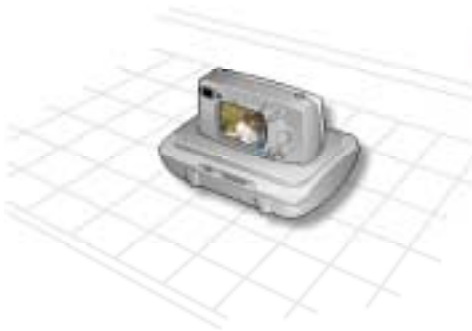

#### Basic Dock

- One touch picture transfer to PC
- Camera battery charges while camera is in dock
  - Camera battery charges in 2.5 hours
  - Camera battery charges overnight
- Dock connects to TV for slide show
- Dock can connect directly to a printer for PC-free printing
- Slot to charge optional 2<sup>nd</sup> camera battery
- Priced from \$39 - \$59



#### Plus Dock

- One touch picture transfer to PC
- Camera battery charges while camera is in dock
  - Camera battery charges in 2.5 hours
  - Camera battery charges overnight
- Dock connects to TV for slide show
- Dock can connect directly to a printer for PC-free printing
- Slot to charge optional 2<sup>nd</sup> camera battery
- Priced from \$59 - \$79



#### Premium Dock

- One touch picture transfer to PC
- Camera battery charges while camera is in dock
  - Camera battery charges in 2.5 hours
  - Camera battery charges overnight
- Dock connects to TV for slide show
- Dock can connect directly to a printer for PC-free printing
- Slot to charge optional 2<sup>nd</sup> camera battery
- Priced from \$79 - \$99